

CATALOG	DESCRIPTION
VC8024	VERTICAL ORGANIZER, BLACK

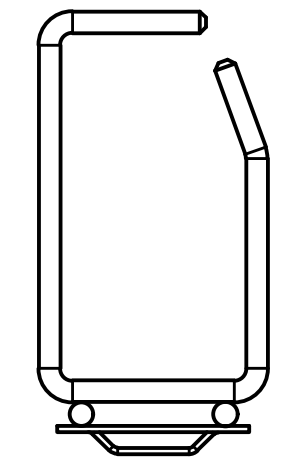

SALES AND SERVICE LABEL

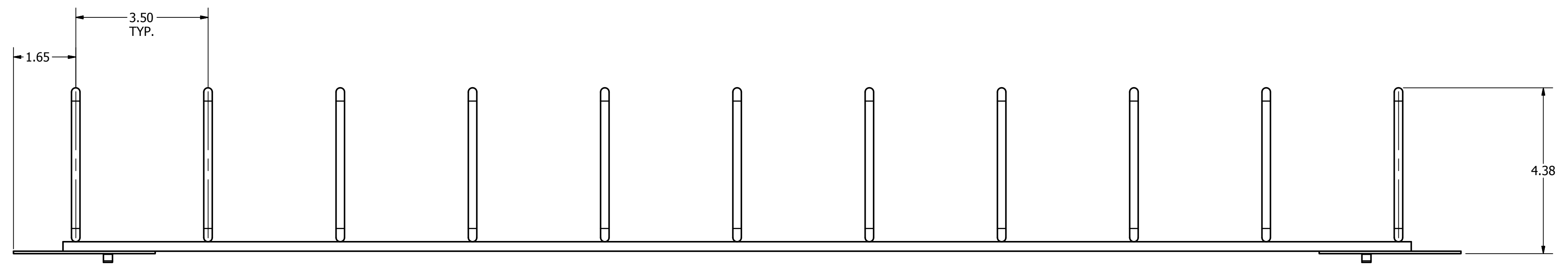
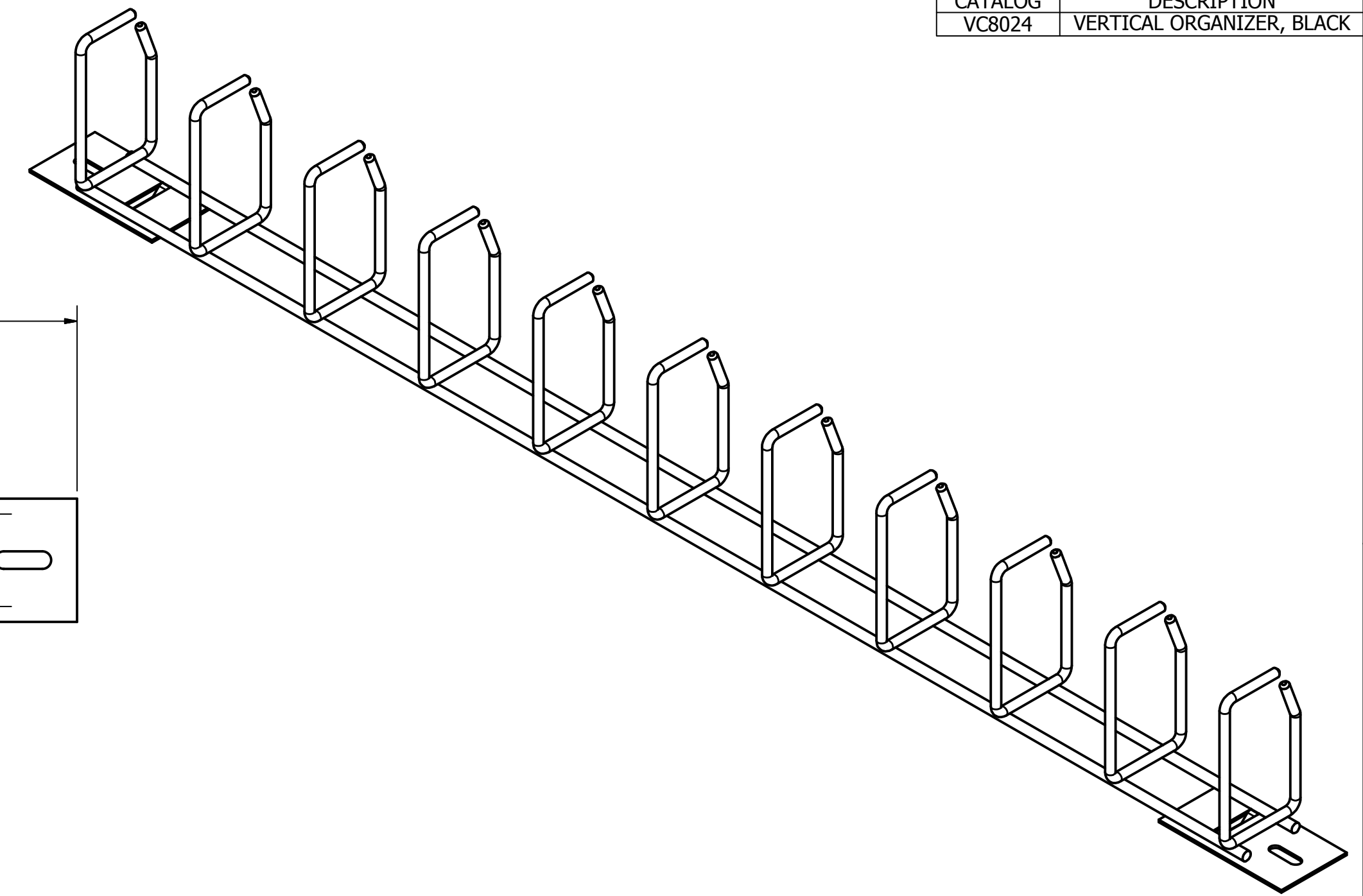
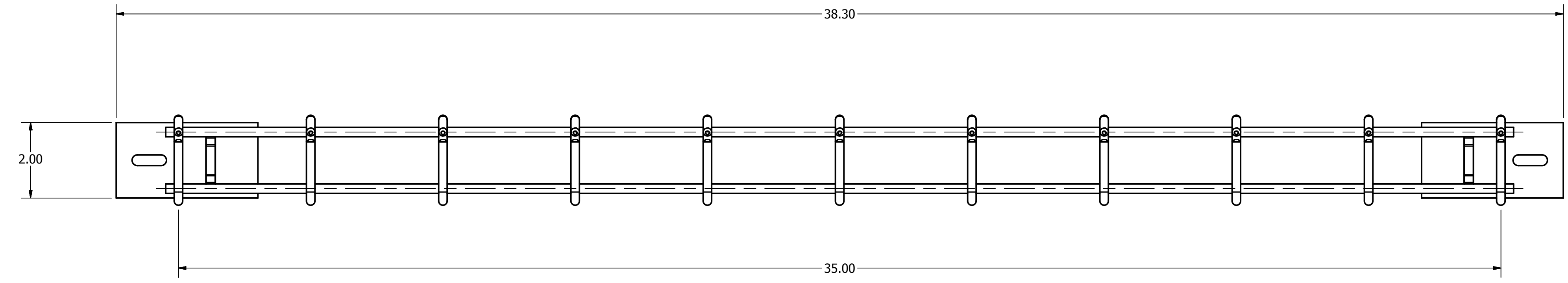
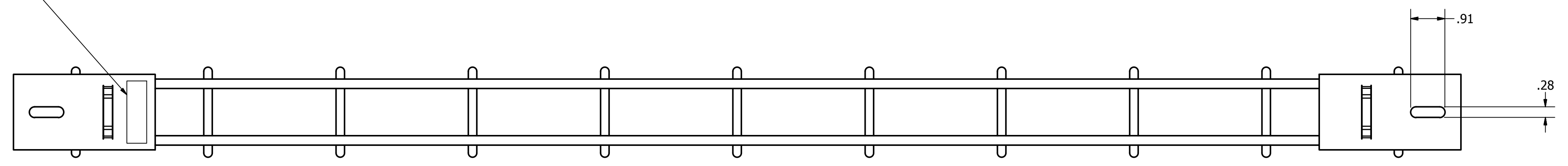

NOTES:

1. MATERIAL: COLD ROLLED STEEL
2. SURFACE FINISH: BLACK POWDER PAINT
3. KIT INCLUDES 2 ORGANIZER ASSEMBLIES AND 2 PUSH PIN FASTENERS.
4. SPECIFICATIONS SUBJECT TO CHANGE WITHOUT NOTICE.

DIMENSIONING AND TOLERANCE PER ANSI Y14.5M-1982 UNLESS OTHERWISE SPECIFIED, DIMENSIONS ARE IN INCHES (MM). TOLERANCES: XX = ±.01 (.25) .XXX = ±.005 (.127) .XXXX = ±.0025 (.0635) ANGLE TOL ±1°

IN ACCEPTING OUR DRAWINGS, BLUEPRINTS, OR SUPPORTING DOCUMENTATION FOR QUOTATION OR OTHER PURPOSES, YOU AGREE NOT TO DISCLOSE TO OTHERS THE IDEAS, INFORMATION, OR DESIGNS SHOWN HEREIN, AND THAT YOU WILL MAKE NO USE OF SAME WITHOUT PERMISSION

PROJECT REFERENCE:	NPD 00048
MATERIAL:	
DRAWN BY:	D.O'CONNOR 8/27/15
CHECKED BY:	
APPROVED BY:	

 **Hubbell Premise Wiring**
HUBBELL INCORPORATED (Delaware)
23 CLARA DRIVE, SUITE 103 MYSTIC, CT 06355

TITLE:		CABLE ORGANIZER FOR RACKS AND CABINETS	
SIZE	DRAWING NO.	REV.	
D	HWS14526C	1	
SCALE:	SHEET 1 OF 1		

1	21332	9/2/15	INITIAL RELEASE	DPO	
REV.	ECN	DATE	DESCRIPTION	CHG BY	APPD BY

Created on INVENTOR